

REVISIONS				
ZONE	REV.	DESCRIPTION	DATE	APPROVED
	B	Updated material callout from AL6061 to AL6061-T6511	9/14/16	AO

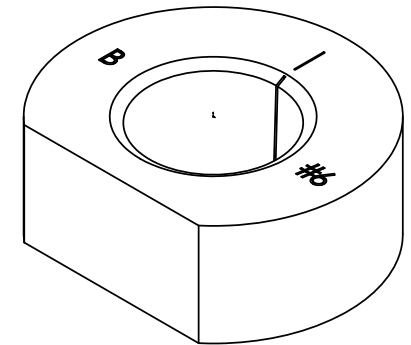
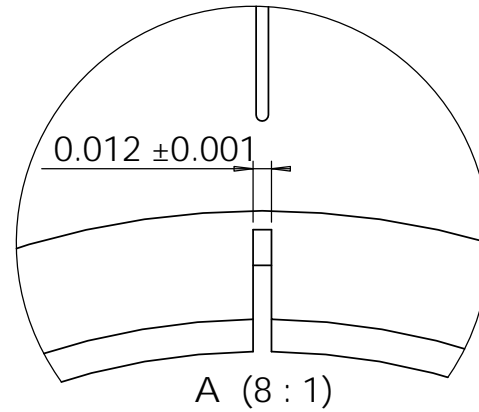
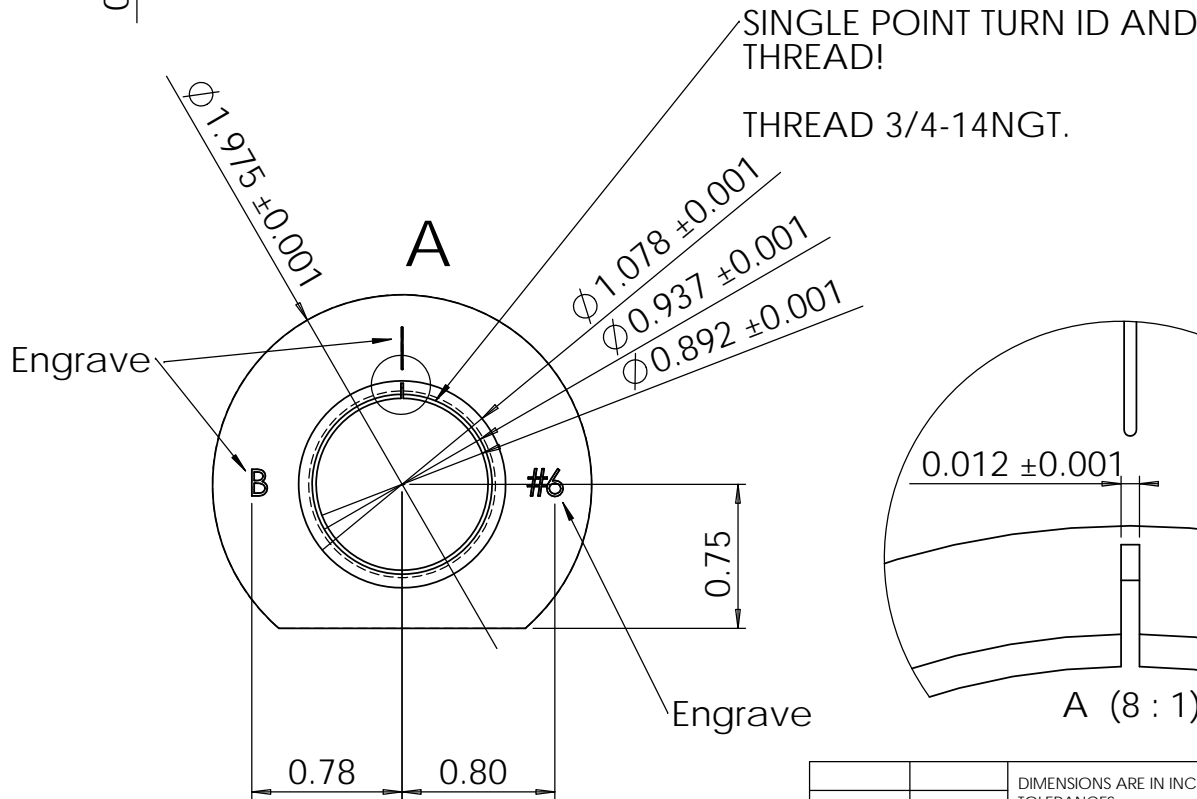
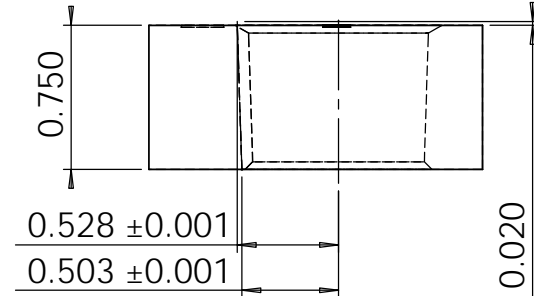
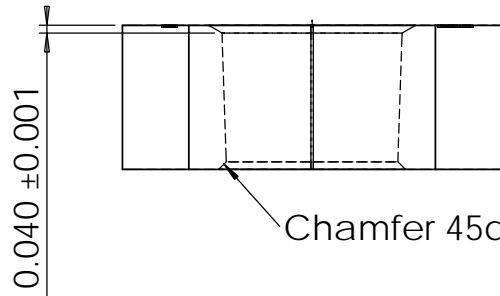

PROPRIETARY AND CONFIDENTIAL
 THE INFORMATION CONTAINED IN THIS DRAWING IS THE SOLE PROPERTY OF SARYNA TECHNOLOGIES LLC. ANY REPRODUCTION IN PART OR AS A WHOLE WITHOUT THE WRITTEN PERMISSION OF SARYNA TECHNOLOGIES LLC IS PROHIBITED.

		DIMENSIONS ARE IN INCHES TOLERANCES: FRACTIONAL ±1/32 ANGULAR: MACH ± BEND ± TWO PLACE DECIMAL ±0.02 THREE PLACE DECIMAL ±0.003		NAME AO	DATE 5/1/08	Saryna Technologies LLC	
		MATERIAL AL6061-T6511		CHECKED		VP Calibration Standard 3/4-14NGT #6	
FINISH Anodize, Type 2, Black	COMMENTS: BREAK ALL EXTERNAL SHARP EDGES UNLESS NOTED. ENGRAVING FONT IS NOT IMPORANT. USE 1/16" BALL END MILL, 0.01" DEEP OR LASER ENGRAVE.	ENG APPR.		MFG APPR.		SIZE A	DWG. NO. VPP-108-6
APPLICATION DO NOT SCALE DRAWING		Q.A.				REVISIONS B	
SCALE:1:1	WEIGHT:	SHEET 1 OF 1					